

# MEIDE VALVE

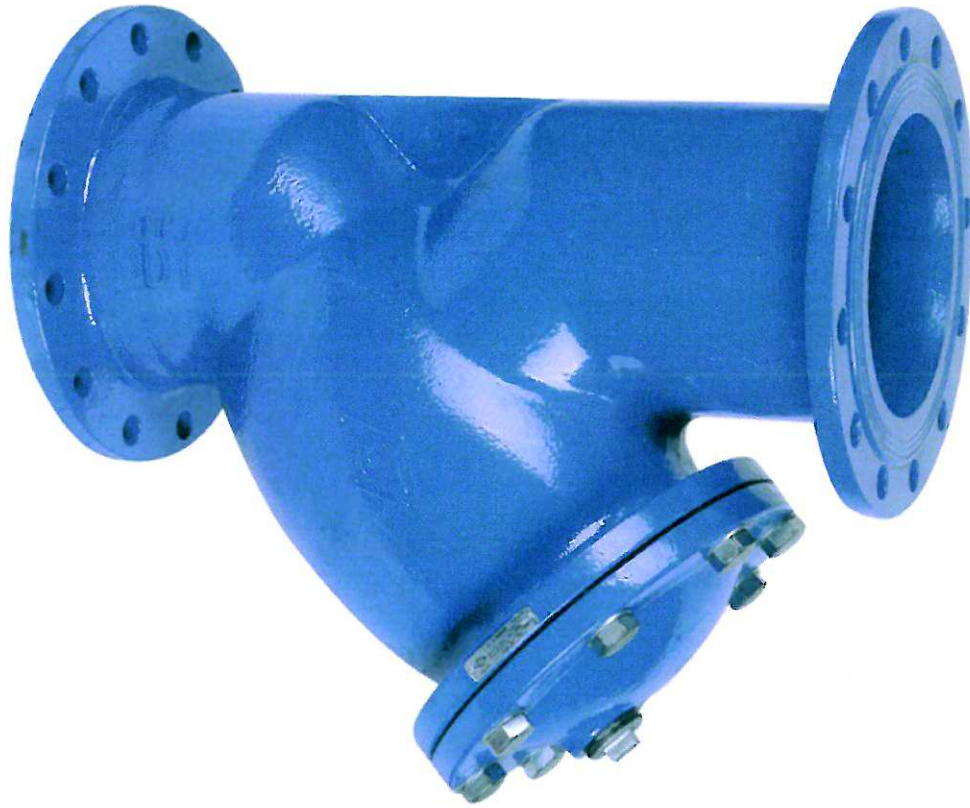

V4

Y-STRAINER

\*Standard: EN12266-1

\*Flange Specification: EN1092-2 PN16

\*Working Pressure: PN10 / PN16

\*Working Temperature: Rubber seal 0-80°C

\*Coating: Fusion Bonded Epoxy Coating complies with BS6920

\*Application: Potable water, Water Distribution Service & Feed lines, Sewage Disposal, Irrigation and Fire Protection Pipe System etc.



JINAN MEIDE CASTING CO., LTD.

# MEIDE VALVE

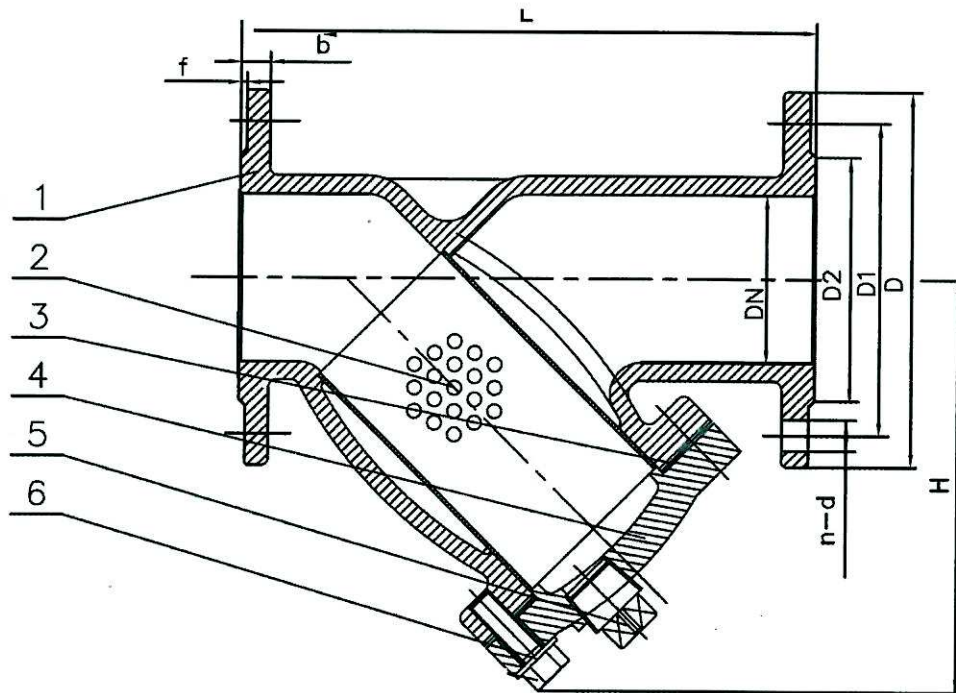

Part No.	Part	Material
1	Valve Body	Ductile Iron EN-GJS-450-10
2	Screen	SS304 / SS316
3	Gasket	EPDM
4	Cover	Ductile Iron EN-GJS-450-10
5	Plug	SS420 / SS316
6	Bolt & flat washer	SS304

DN		PN	Dimensions(mm)							
Inch	mm		L	D	D1	D2	b	n-Φd	f	H
1.5"	40	10/16	200	150	110	90	19	4-Φ19	3	140
2"	50	10/16	230	165	125	99	19	4-Φ19	3	140
2.5"	65	10/16	290	185	145	118	19	4-Φ19	3	175
3"	80	10/16	310	200	160	132	19	8-Φ19	3	198
4"	100	10/16	350	220	180	156	19	8-Φ19	3	229
5"	125	10/16	400	250	210	184	19	8-Φ19	3	287
6"	150	10/16	480	285	240	211	19	8-Φ23	3	304
8"	200	10	600	340	295	266	20	8-Φ23	3	370.5
		16						12-Φ23		
10"	250	10	730	405	350	319	22	12-Φ23	3	469
		16			355			12-Φ28		
12"	300	10	850	460	400	370	24.5	12-Φ23	4	540
		16			410			12-Φ28		