

MEIDE VALVE

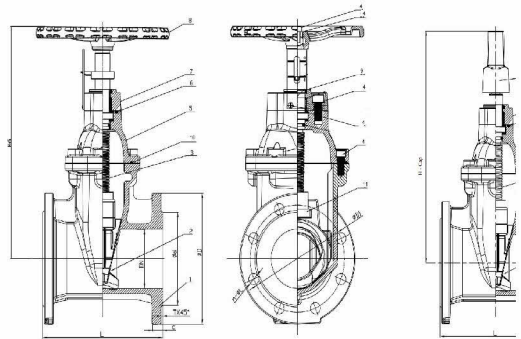

GATE VALVE- Z45X/A1, Z45X/A2, Z45X/A3

*Standard: EN1074-1 & 2

*Flange Specification: EN1092-2 1.0MPa / 1.6MPa

*Working Pressure: PN16

*Working Temperature: 0-80°C

*Coating: Fusion Bonded Epoxy Coating complies with BS6920

Part No.	Part	Material
1	Valve Body	Ductile Iron EN-GJS-450-10
2	Resilient Wedge disc	Ductile Iron EN-GJS-450-10 + EPDM
3	Stem	Z45X/A1 – SS316 Z45X/A2 -- SS431S29 Z45X/A3 – SS420
4	Bonnet	Ductile Iron EN-GJS-450-10
5	O-ring	EPDM
6	Gland Flange	Ductile Iron EN-GJS-450-10
7	Stem Cap	Ductile Iron EN-GJS-450-10
8	Hand wheel	Ductile Iron EN-GJS-450-10
9	Ring Wiper	EPDM
10	Bonnet Gasket	EPDM
11	Stem Nut	Z45X/A1 & Z45X/A2 -- CC331G Z45X/A3 – CW617N

DN		PN	Dimensions(mm)							
Inch	mm		L	H	D	D1	d	C	T	n-d
2"	50	16	178	218	165	125	99	19	3	4-Ø19
2.1/2"	65	16	190	232	185	145	118	19	3	4-Ø19
3"	80	16	203	281	200	160	132	19	3	8-Ø19
4"	100	16	229	316	220	180	156	19	3	8-Ø19
6"	150	16	267	420	285	240	211	19	3	8-Ø23
8"	200	16	292	490	340	295	266	20	3	12-Ø23